

MS21 TRANSCRIPTION TABLE

SET-UP INSTRUCTIONS



**Congratulations on your purchase and thank you from everyone at
MSR, LLC.**

You are now the proud owner of a MSR, LLC. MS21 Transcription Table.

Read the instructions through once completely before attempting to set up

Unpack your turntable from its shipping carton. Notice the packing list located in on pages 12 and 13 of the manual. Inventory the items in your shipping containers and verify that all items are included.

Your MS turntable has been pre machined for the tone arm you have purchased. If this is not the case and you have purchased an MS with a blank sub chassis mounting boss, the following steps must be observed.

Place the turntable upside down on two stacks of books located on each end of the table. Take care not to bend the motor shaft, damage the cable strain or scratch the table.

Loosen the thumb nut that secures the tuning weight to the sub chassis and remove it from its assembly. Tighten the wing nut back onto its assembly so it will not be lost during transport.

Disconnect the sub chassis ground wire from the grounding lug. Remove the three spring assemblies which include a wing nut, thrust washer, thrust bearing, and the spring (see fig.1).

Gently remove the sub chassis from the turntable plinth. Notify MSR, LLC. Of your intent to mount your arm of choice and send the sub chassis to us for machining.

If you have pre ordered the table machined for a certain tone arm pattern then start with these steps.

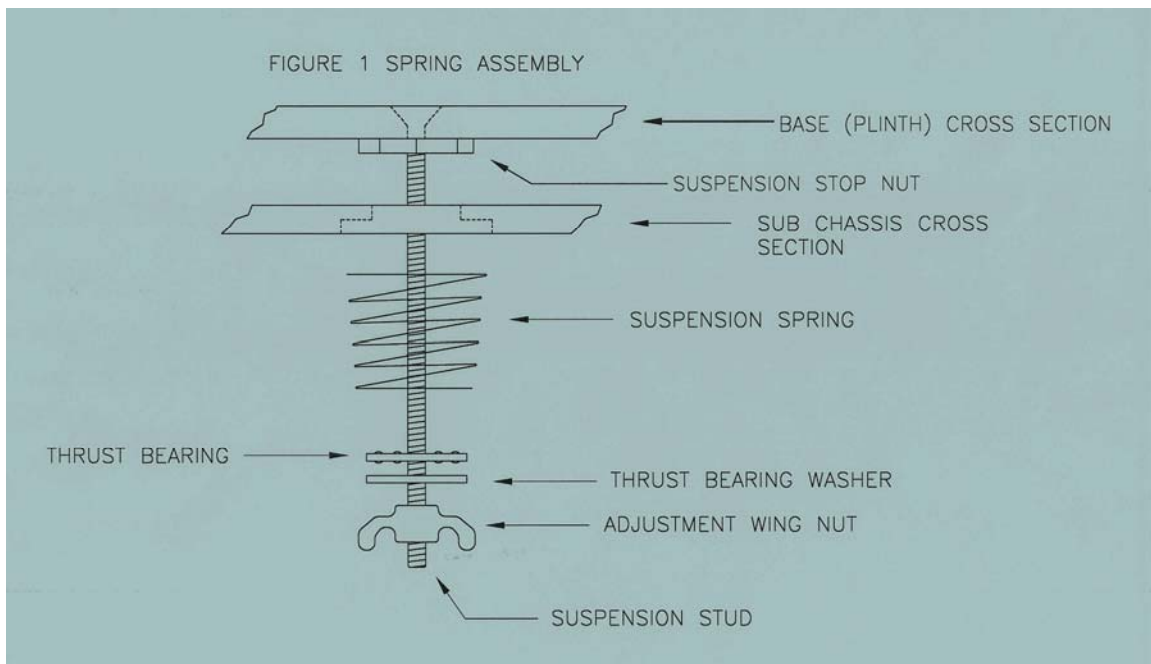

First place the turntable on a surface that is level or the surface in which is to be set upon for playing. The adjustment for leveling will now be made. Use the two miniature levels supplied to perform this. By placing one on the Y axis and another on the X at mid point (see fig. 2) and turning the leveling feet in/and or out, observe the two axis simultaneously until the plinth is level. You will not have to perform this as a major

operation again. But once the table is set in its final resting place, you may want to double check and make minor adjustments as necessary.



Figure 2 - Leveling

Your MS21 is equipped with leveling feet that elevate the table high enough so you can access the underside for tuning weight and sub chassis adjustment. But if you are having trouble accessing the underside for suspension adjustment then a good method has been noted below.

**NOTE: A good method of obtaining access to the underside of the turntable is to place it on a dining room table with the leaf of the dining table removed or placing the table on 2 equally high stacks of books between the leveling feet.*

Mount your arm as per the manufacturers' instructions. Route the tone arm wiring where it has as little effect as possible on the sub chassis movement. Use the provided cable strain system (fig. 3) or p-clip located in side the base (plinth) at the bottom rear of the unit half way between the blank off plate and tone arm cable exit slot to secure the wiring. Remember the tone arm wire stiffness and routing can adversely affect the operation of the sub chassis. The wire needs to be very flexible (some tone arm output wiring can be modified to make it more flexible).

The tuning weight as shown in fig. 4 is already mounted. The slotted end of the weight should be facing towards the tone arm and slid approximately half way to the end of the slot.



Figure 3 – Cable Strain System

Remove the dust plug from the bearing and look down into it. There is a space between the round thrust ball at the bottom and the bearing sleeve. This space is the oil storage well. Pour 1-1/2 capfuls of oil in the bearing or use an eye dropper for this procedure. Install the inner platter shaft into the bearing and allow the shaft to seat. Do not force. This process takes a little time. The outer platter and clamps can be placed on the inner platter to expedite the process. As the platter shaft sinks into the bearing it dissipates some of the oil in the well and forces it between the shaft and the bearing. This allows the shaft to ride on a film of oil. If too much oil was placed in the bearing, the shaft will not completely seat. When you think the thrust ball on the spindle shaft is seated, this can be verified easily by lifting the shaft slightly and releasing it quickly. The vacuum created will pull the shaft down and a click will be heard when the shaft thrust ball hits the bearing ball in the bottom of the bearing housing. You will notice when the shaft seats in the bearing that excess oil will spill out into the recessed area in the top of the bearing. (There should be no oil collected in this area when the turntable is not operational)

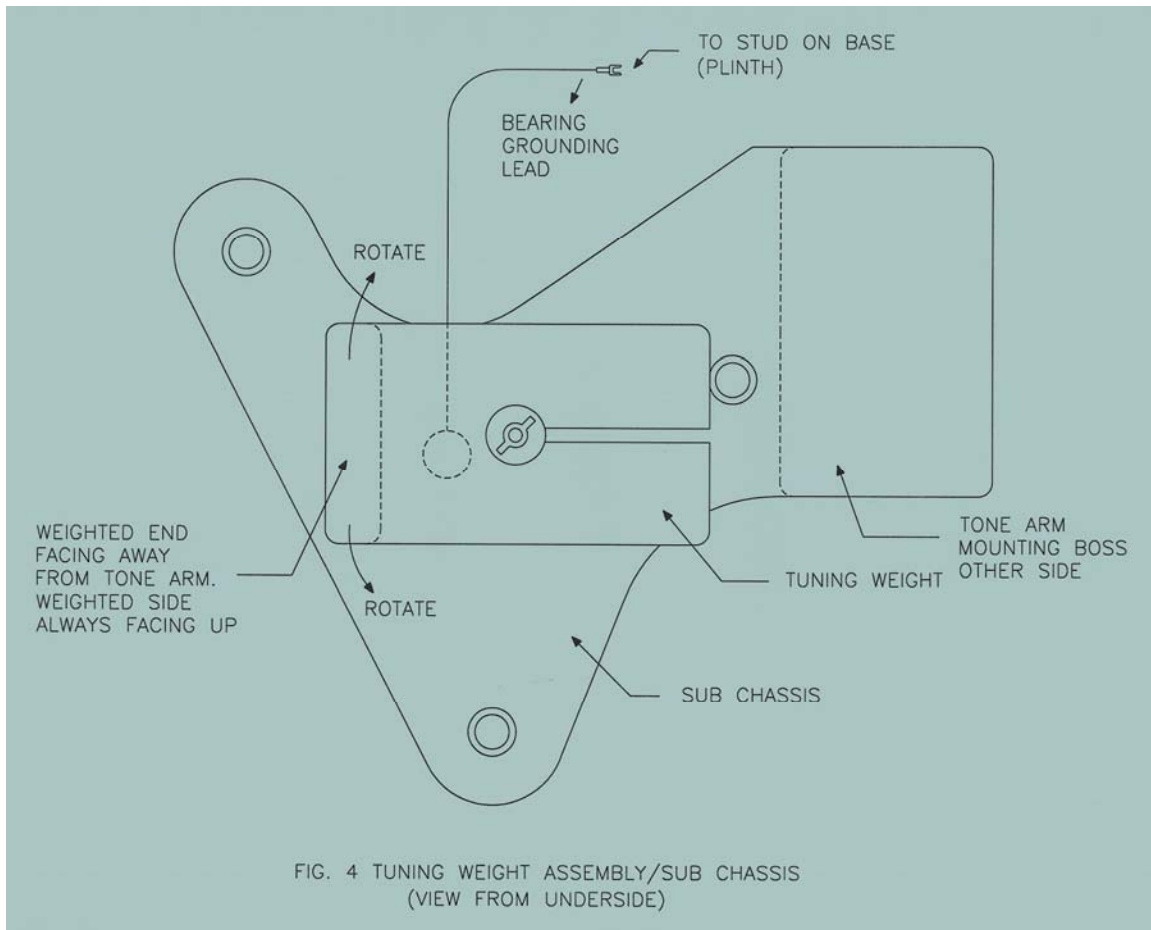

That is a sign that too much oil was put into the oil well. To correct this problem when seating the shaft into the bearing well, let the shaft seat, then pull it out and wipe excess oil off of the shaft with a lint free towel. Repeat the process until no oil comes from the bearing when the shaft is seating. This collection area also has another purpose. When the platter assembly is rotating, oil will creep up between the shaft and bearing sleeve and spill out the top of the bearing. This recessed area will contain the oil and when the table is not in use, the oil will drain back down into the well.

Do not install the belt. It is important how ever that you install the platter system which includes the ring and center clamp as well as the vinyl. You are adjusting the suspension with approximately all weight that will normally be loading the springs during an audio session.

The MS turntable requires two primary adjustments in order to set the sub chassis for its proper balance (wing nut adjustment and tuning weight adjustment). The first adjustment is done via the three wing nuts that retain the spring assemblies of the suspension system. By turning these three wing nuts clockwise viewed from the bottom of the turntable they will rise towards the top of the table lifting the sub chassis and platter system along with their movement. Turning the three wing nuts counter clockwise will lower the whole system. These wing nuts have nothing to do with the actual tuning of the sub chassis, the only function that they perform is to raise, lower and level the sub chassis and platter system within the base (plinth) itself. With the wing nuts you can raise the sub chassis all the way to the point where it hits the stop nuts that secure the suspension studs located between the sub chassis and underside of the base (plinth). Or, you can lower the sub

chassis to the point where the underside of the co polymer platter strikes the motor pulley. If these wing nuts are adjusted unequally, then the sub chassis will tilt causing it to be unlevel with reference to the top of the base (plinth). One of the main points in having proper turntable set up is the float of the sub chassis; be sure that it floats and be sure that it is level with the base top.

**NOTE: The sub chassis arm-mounting boss does not have to be even in height with the top of the base (plinth), but only in close proximity. What is most important is that the mounting boss is level.*

So, the first set up adjustment to do is to adjust the wing nuts to the point where the sub chassis floats and does not touch the suspension stop nuts or the underside of the co polymer platter does not touch the motor pulley.

**NOTE: This being said, the bottom of the aluminum resin drive platter should not be rubbing the top plate of the base (plinth). Find an equal balance. Generally speaking, the distance between the aluminum resin drive platter and the top plate of the base (plinth) should be roughly 1/4 to 3/16 of an inch.*

As you do this adjustment, you can take a measurement (with the scale supplied) from the top of the clamping ring to the top of the base (plinth) to make sure that the distance is equal all the way around the platter or you can use a 4 point digital level such as the Cartridge Man's. Either method is acceptable. This will assure you of having the sub chassis level with the top of the base (plinth).

Once you accomplish this, we are ready to adjust the tuning weight, which is the second primary adjustment. Remember that tuning the sub chassis is accomplished by shifting the tuning weight and this shifting of the tuning weight will transfer the effective mass of the sub chassis from one spring to the other. At the properly tuned point, all the mass will be equally distributed and the springs will be compressed equally or close to equally.

Now the tuning weight needs to be adjusted. The measurement for equal spring compression length can be taken from the bottom of the sub chassis to the bottom spring. The heavier the tone arm, the more compressed the arm mounting spring (spring closest to the arm mounting boss) is. Loosen the thumb nut and slide the tuning weight in a direct line away from the arm-mounting boss until all springs are equally compressed.

**NOTE: When adjusting the tuning weight, the spring length is changed by either more or less compression of the spring. This change in length will cause the sub chassis to tilt and necessitate the re-adjustment of the wing nuts. So it will be necessary to switch from wing nut adjustment to weight adjustment. The heavier the tone arm, the further away from the tone arm the tuning weight will have to be moved. This adjustment causes a transfer of weight from the arm mounting spring to the platter springs.*

Notice also that rotating the tuning weight will shift the mass to the front or back platter springs, causing an opposite reaction of the two springs (one grows longer and the other shorter). It will be necessary to rotate the tuning weight to achieve equal pressure distribution on the platter springs. Once you have the spring compression equal, check to see if the free-floating aspect of the sub chassis is okay. If not, readjust the suspension wing nuts. Then go back and check the spring compression. Repeat this procedure until the springs are equally compressed and the sub chassis is floating in a level manner.

Remove the clamping system and platter, install the belt and replace the platter. Plug the motor power cable into the motor socket at the rear of the table and into rear of the power supply. The connectors are keyed so they cannot be reversed. Your MS21 is supplied with a 4 ft. power cable to facilitate convenient placement of the unit. Turn on the mains switch located at the rear of the unit. The purpose of this switch is to keep the electronics warm within the unit. It is recommended that the mains switch be turned on sometime before your audio session, as the crystal controlled oscillator will stabilize. Your M/S motor power supply is switch able from 33 to 45rpm. This power supply has been wired for voltage in the country to which it was shipped at purchase. If you the customer move to a country which has different power requirements, the unit may be shipped back to the factory and reconfigured for proper voltage.

With the clamps installed, turn the unit on and check to see if the belt is riding on the crown (center) of the motor pulley. This check is very important since improper belt position will generate noise. The belt will usually self center, but if the belt is not riding on the crown, first check to make sure that the sub chassis is level and the clamping ring is an equal distance at all points from the base top plate. Then, if necessary, the motor tilt can be adjusted by loosening alternating motor mounting screws, thus changing the motor pulley belt ride position. Under each motor mounting screw is a spring. By loosening one screw, the motor shaft will tilt. Loosen the right screw (facing the turntable) and the motor shaft will tilt to the left. If the belt is riding low, loosen the right screw. If the belt is riding high, loosen the left screw. With the suspension adjusted properly and at the correct height, it has been determined that the belt will ride somewhere close to the center of the drive platter.

If your turntable is not at its permanent place of operation place it there at this time. Your table has been supplied with 4 rubber discs. Place these discs below the feet and sit the table down on them. They are used for two reasons – 1) They will help to couple the table to your platform and 2) they help to avoid scratching your furniture / or stop the table from sliding off of a slippery platform. Just make one quick check to ensure that the plinth is level and make slight adjustments if necessary at this time. If any adjustments are to be made, slightly lift the side of the table where the adjustment is to be made so the foot can be turned effortlessly. Now remove the outer platter and add the motor damping oil. Pour the oil into the gap between the motor and motor pod filling approximately ½” from the top.

To use the periphery clamping system, remove the clamps; place the record on the platter; place the periphery clamp over the record; then the inner clamp on the spindle. A record may be played without using the periphery clamp by leaving it in place on the platter. There is a recess built into the periphery of the platter to accommodate this.

While using the periphery clamp with certain cartridges, it will be necessary to move the cartridge inward slightly in order to start the record; otherwise the cartridge body will touch the clamp. We experimented with different thickness of the clamping edge, but in order to absorb energy, we chose the configuration that we have now. We did, however, check for clearance with many cartridges and found only a few needed to be placed inward at the start.

The center screw down clamp should only be tightened enough to make contact with the record and remove any warps.

CAUTION: OVER TIGHTENING CAN CAUSE DAMAGE.

During start up, a noise can be emitted from the belt as it seeks the center of the pulley's crown. This noise is normal.

The bearing has an embedded ground lead that is attached to a stud which travels through the rear of the base (plinth). There are two fastening thumb nuts – one on each side. Your table also comes with a 4' ground wire. If you live in a dry area and experience static, attach the wire to the ground stud of your phono preamp. This stud is useful if you have a short tone arm ground wire which you can attach to the stud, then with the supplied ground wire, run on to your pre amp.

TURNTABLE STABILITY

Be sure the stand or platform supporting the turntable is sturdy. The MS turntable, because of its mass and chosen materials, is by all purposes stable in its self and quite immune to air born and foot born vibrations. But, if you are still experiencing a problem with the stylus skipping across the record due to footfalls (walking across the floor); this problem is related to the foundation that the table support system is sitting on. A suspended type turntable (one that has an internal suspension system), is susceptible to footfall problems because of its resonant frequency point, which is in the frequency area of footfalls. If you live in a building that has very shaky floors, you can isolate the turntable in the following manner. Install wall mounted audio platforms or shelving on an outside load-bearing wall, which is a wall that comes in contact with the foundation of the building. This type of mounting arrangement should eliminate the problem of footfall. If footfall problems still occur or you do not wish to mount a shelf on the wall, then try this next idea. Looking in the basement of your house, notice the floor joists are resting on the foundation and run across and rest on the foundation on the opposite side. Where the floor joist exits the foundation is the spot to place the shelving. In most homes, the floor joists are 16" on center. By setting your shelving over the floor joists, there will be one joist every 16" underneath your shelving.

Obtain two screw type house jacks. These can be purchased from a hardware store or your local building material supply store. You will also need concrete cap blocks or stepping-stones. On the floor joists that are under the cabinet, place the jacks in position in front of the shelving, approximately 3 to 4 feet from the foundation. Put the concrete cap blocks or the stepping stones level on the ground, place the jacks, and then raise the jacks up to the floor joist. Make contact and turn the jack $\frac{1}{2}$ to $\frac{3}{4}$ of a turn past that point. You do not want to try to raise the house. All you want to do is stop the movement of the floor joists. This will put a very solid foundation in the area where the shelving sits since the other end of the floor joists are supported by the foundation of the house.

THE USE OF SPIKED FEET WITH THE MS21 TURNTABLE

Can spiked feet be used with the MS turntable? Yes, under the following circumstances. Spiked feet are transmitters of energy, not isolators. When spiked feet are properly placed under a speaker (an energy generator), the vibration energy generated by the speaker is drained from the speaker cabinet into the floor. This works similarly to a heat sink connected to a transistor. The process of removing energy from the speaker cabinet will greatly improve the sound quality. A turntable is a non-generator of energy. Energy enters the base (plinth) of the turntable via both airborne input and mechanical vibrations from the stand or platform the turntable is sitting on. Due to the usually smaller size of the turntable base (plinth), it is less susceptible to airborne energy than the stand or platform. A turntable needs to be either de-coupled or energy sinked depending upon the stand or platform used with the turntable. If the stand or platform is of a very rigid, vibration free construction and is less susceptible to airborne acoustic input than the turntable base (plinth), use spiked feet under the platform. Airborne energy entering the turntable base (plinth) will drain into the better-damped stand or platform. If the stand or platform is more susceptible to vibration than the turntable base (plinth), then use isolation feet to de-couple the turntable stand or platform.

The easy way to determine this is to experiment by playing a full frequency range recording and physically feeling the stand or platform vibration. But as an experiment and self-education try both spike feet and isolators and see which sound the best. The stand or platform should almost always be coupled to the floor with spiked feet. If your turntable is sitting on a platform that is mounted to a load-bearing wall, this works very well if the wall is rigid. If the wall or floor that the stand or platform is resting on or is attached to vibrates to a greater amount than the platform or stand, which is an unusual situation, then the stand or platform must be isolated. A tip about using a tripod turntable stand on floors susceptible to footfall movement is that the stand acts as a lever. A small movement on one floor spike is amplified by the height of the stand. If a problem of this nature does arise, use a large rigid plate, preferably steel, wood or granite between the floor and the stand.

MAINTENANCE

Once a year, check the belt for wear and elasticity. Clean the belt motor drive pulley and the inner platter drive surface with alcohol. Check and replenish bearing oil and damping fluid if necessary.

CLEANING AND CARE

The material used for the construction of the table is impervious to most all chemicals. While the material is dense and strong in nature it is also in a sense fragile in as much as that it scratches easily.

It is recommended that you clean your table with a lint free cloth damped with water or isopropyl alcohol.

CAUTION: Do not apply chemical record cleaners or preservatives while the record is resting on the platter of the turntable. Chemical cleaners and preservatives may DESTROY the platter and de coupling mats.

*NOTE: Do not contact the platter or de coupling mats with alcohol. You will destroy them. Use a towel damped with water.

*NOTE: The MS21's base (plinth) and most other mechanical parts are manufactured from an ultra dense cell cast Co polymer resin material that can have migrations of gas which can cause very small dispersions at the surfaces of the materials. This is a minimal occurrence but is a natural occurrence in this material. In so far as sonic ability, this material is sonically superior to any other material in which we have tested. We think it is also very attractive when machined properly and we hope you will think so also. Care should be taken when handling your MS21.

SPECIFICATIONS

Model:	Merrill-Scillia 21 (MS21)
Speed	Dual Speed Digital Power Supply with 33 RPM Pulley
Control:	
Drift:	< + .002%
Wow/Flutter:	WTD. / DIN./3.15 KHZ <.1%
Dimensions:	W: 20.375" (517.525mm), 19.500" (495.3mm) foot center to center. D: 16.250" (412.750mm), 19.000" (482.6mm) with Cable Strain, 12.500" (317.5mm) foot center to center. H: 6.500" (165.1mm) with leveling feet screwed half way out from plinth. H: 11.500" (292.1mm) total height with dustcover.
Weight:	70 lbs. (31.751 kg.) Turntable 10 lbs. (4.536 kg.) Power supply

Thickness of tone arm mounting boss and sub chassis area: 1.500"

**NOTE: Because of the thickness of the sub chassis mounting boss, the under side of the sub chassis may have to be machined with a relief to accommodate some model tone arms that require such clearance. Once the sub chassis is sent to the manufacturer for machining, we will determine if this operation needs to be preformed.*

PACKING LIST

SHIPPING CONTAINER 1.

In this container you will find three smaller containers in which contain the following items:

Box 1:

Dust cover _____

Box 2:

Platter assembly which includes:

Drive platter _____

Outer platter _____

Periphery clamp _____

Center screw-down clamp which includes:

Stainless steel base _____

Clamp washer (separate from clamp assembly) _____

Co Polymer clamp top _____

Accessories which include:

Motor damping fluid _____

Belt _____

Bearing Oil _____

Grounding lead _____

4 rubber discs _____

Tools which includes:

Scale _____

2 miniature levels _____

1/16" Allen wrench for cable strain cap _____

3/32" Allen wrench for cable strain removal _____

7/64" Allen wrench for blank off plate removal and p-clip fastening _____

Manual: How to set up and tune your TT and Tone arm _____

Instruction manual _____

Box 3:

Base (plinth) with motor assembly/pulley, cable strain system and sub chassis
(including tuning weight assembly) installed ____

SHIPPING CONTAINER 2:

Motor power supply____

Motor connection cable____

Power cord____

MS21 TURNTABLE WARRANTY

The warranty for the MS turntable is five years. If any defects occur with your turntable during the years following the date of your purchase, please note the following paragraph.

The MS turntable is of a modular design with the exception of the plinth its self. That is; each part of the MS turntable is a module that can easily be replaced by the dealer or the owner with a minimum amount of effort. If any problem should arise, contact your dealer or MSR, LLC. There should be very few times if any that the turntable would have to be returned if ever to MSR, LLC for repair. If a problem occurs which necessitates the return of the turntable, we ask that you call MSR, LLC for a return authorization. **No return will be accepted without prior approval by MSR, LLC.** Upon receiving approval from MSR, LLC, please follow these instructions carefully.

1. Remove the tone arm. Repack the turntable in the original carton and ship to the address provided. Be sure to insure the turntable for the full purchase price.
2. Your unit will be restored to normal operating condition without cost to you for parts (belt excluded) and labor. The only charge to the owner is shipping to and from the manufacturing facility.
3. This warranty applies only to the turntable under normal circumstances and excludes damage caused by abuse, misuse, or negligence to this product and acts of God which includes - fire, flood and other external causes.
4. Any unexpired portion of this warranty may be transferred to another owner should you choose to sell or make a gift of your MS turntable.
5. To transfer this warranty to a new owner, write to MSR, LLC for a warranty transfer at no charge.
6. This warranty does not apply to any unit which has been repaired or altered by other than the company's own service representative.

Please remove this page and mail to: MSR, LLC. For your Warrantee Registration

MSR, LLC.
P.O. BOX 539
NORTH BRANFORD, CT. USA 06471
+1.203.671.5776

5 YEAR LIMITED PRODUCT WARRANTY

Name _____

Street Address _____

Apartment _____

City _____

State _____

Country _____

Postal Code _____

Telephone _____

Model Purchased _____

Serial Number _____

Date Purchased _____

Authorized Dealer Name _____